

# VF-3·5·6

## Handling manual for CONVUM filter

Read the handling manual without fail before using the filter and keep the manual with care.

### ! CAUTION

1. Organic solvents such as thinner and trichloroethylene should not be used for the cleaning of acrylic cover, filter element or O sealings. It may cause quality faults such as crack.
2. This product is designed for the filtration of vacuum line and should be used for this purpose only. Danger level caution will arise in the usage at the line of compressed air.

### How to disassemble and clean

1. Turn and detach the knob screw and take off the acrylic cover.
2. Remove the O sealings (S-42, S-6) and element from the body. Please do not bend or lose the O sealings.
3. The usage of the air-blower will remove dusts and stuck to some content. Please exchange the element if the removal can not be done appropriately.
4. Please pay attention to the handling of the element, as it is very soft and deformable.

### How to construct

1. Insert O sealings (S-42, S-6) and a filter element into the body.
2. Please make sure of the marking on the element down:  
(VF-3 with red, VF-5 with green, VF-6 with blue)
3. Please assemble an acrylic cover and a knob screw to the body. The standard torque of 0.29 Nm is suitable.

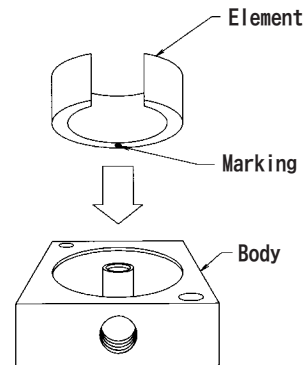

### Specifications

Model name	VF-3	VF-5	VF-6
Diameter of the connecting part	Rp1/8	Rp1/4	Rc3/8
Pressure bearable / MPa	0.5		
The range of Pressure applied / kPa	0~-95.8		
The range of Temp. applied / °C	0~60		
Material	Body	Aluminum diecast	
	Acrylic cover	Polycarbonate	
	Element	Polyvinyl formal	
Average diameter of filter porousness / μm	130		
Weight / g	90	150	235
Diameter of CONVUM nozzle	≦ φ1.0	≦ φ1.5	≦ φ2.0

### Structure

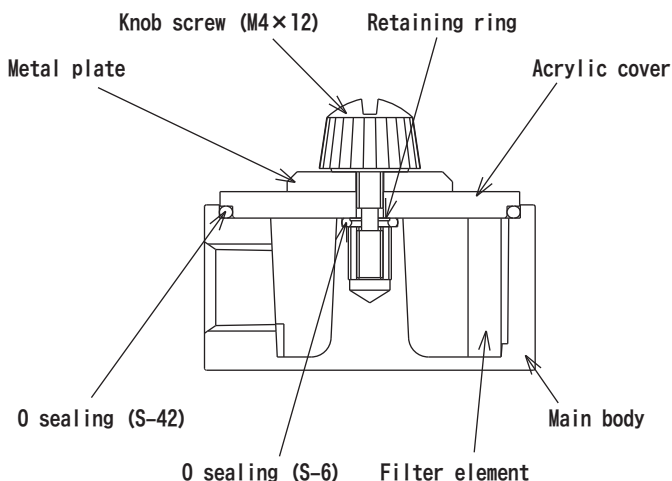

### ! CAUTION

- \*1 Please keep the switch off the air flow or power when the parts proceeded.
- \*1 An expert with technical knowledge should exchange parts and disassemble.
- \*1 Please keep the parts disassembled. The performance will drop without failure of parts.

Outline drawing

VF-3

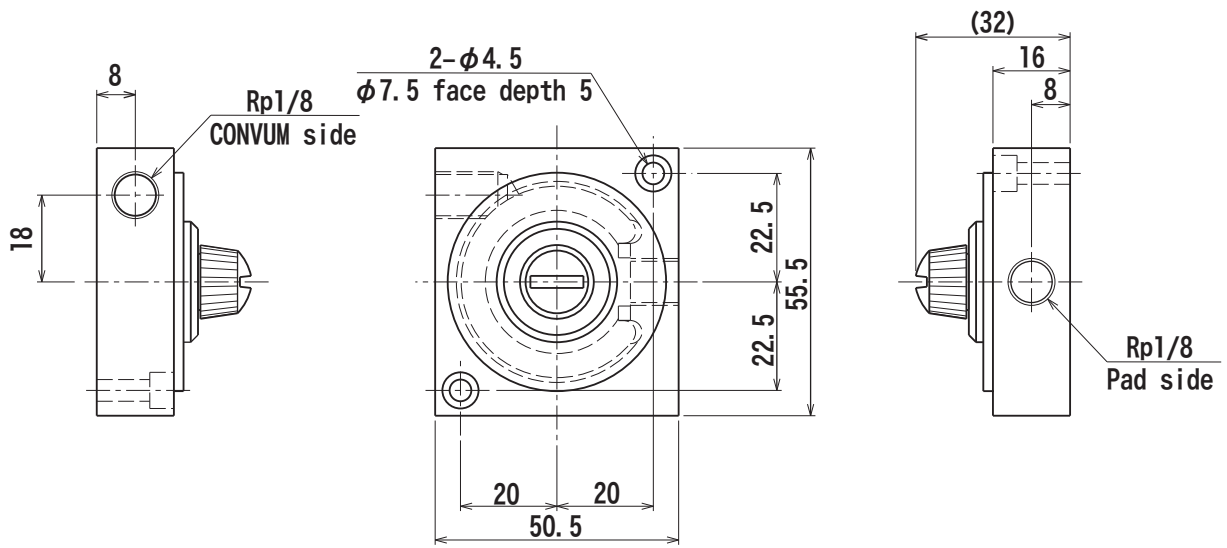

VF-5

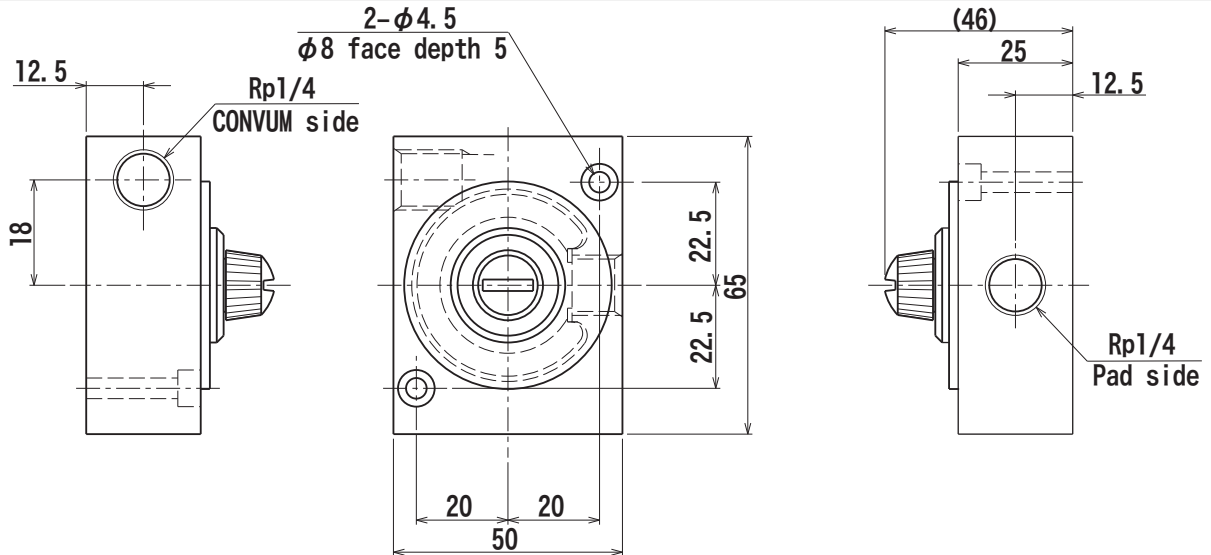

VF-6

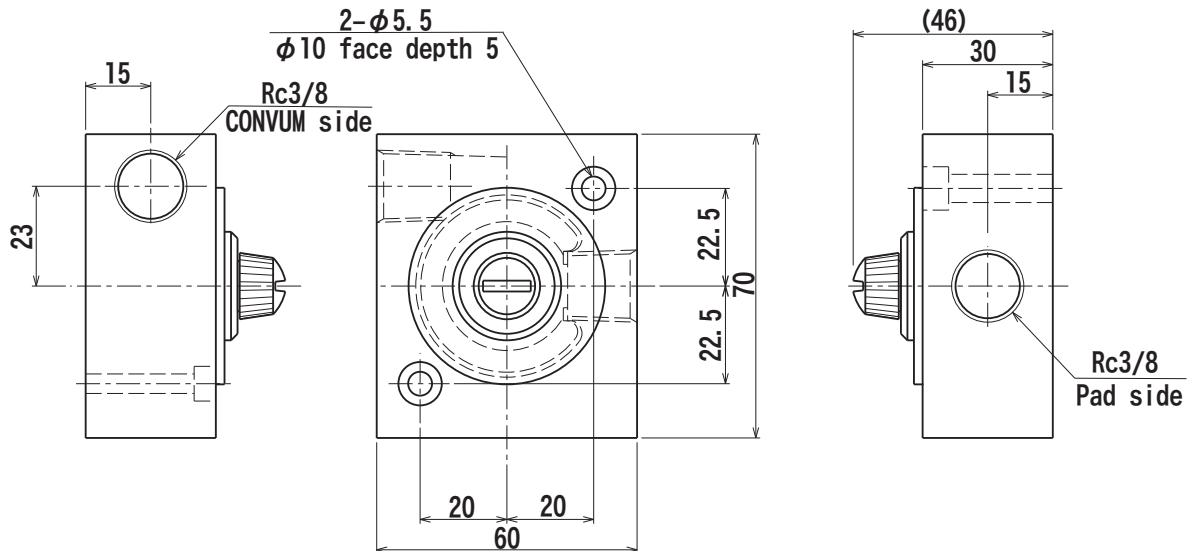

**CONVUM**

<http://www.convum.co.jp>