

快速接头 WP系列

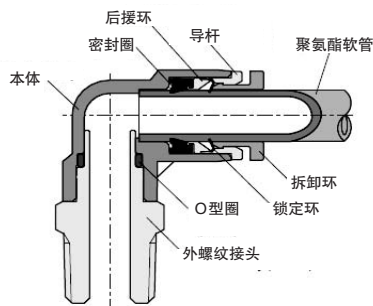

特长

- ◆接头的构成零件最少6部分。
- ◆紧密的与软管连接，容易拆卸的新型锁定环。充实的机能使配管作业更顺利更确实。
- ◆减少软管的连续操作力，保持高密封性的密封圈是高信赖性的秘诀。
- ◆标准采用PA+F/G(聚酰胺)树脂。

规格

| | 单位 | |
|--------|-----|--------|
| 使用流体 | | 压缩空气 |
| 使用温度范围 | ℃ | 0 ~ 60 |
| 最高使用压力 | MPa | 0.9 |
| 最低使用压力 | kPa | -100 |
| 适用软管 | | 聚氨酯软管 |

注)使用压力为温度20℃时的数值。

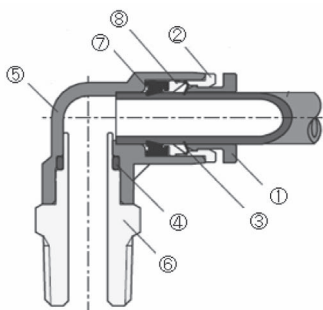

| 零件No. | 零件名称 | 材质 |
|-------|-------|---------------|
| ① | 拆卸环 | PA + F/G(聚酰胺) |
| ② | 导杆 | 铸锌 |
| ③ | 锁定环 | SUS(不锈钢) |
| ④ | O型圈 | NBR(丁腈橡胶) |
| ⑤ | 本体 | PA+F/G(聚酰胺) |
| ⑥ | 外螺纹接头 | 黄铜 |
| ⑦ | 密封圈 | NBR(丁腈橡胶) |
| ⑧ | 后援环 | 铸锌 |

型号

订购方式

注)订购单位为1组(10个)。

WPC 06 - 01

| | | | |
|-----|----------|-----|------|
| M5: | M5 × 0.8 | 01: | R1/8 |
| 02: | R1/4 | 03: | R3/8 |
| 04: | R1/2 | | |

| 适用软管外径 | | | |
|--------|-----|-----|------|
| 04: | 4mm | 10: | 10mm |
| 06: | 6mm | 12: | 12mm |
| 08: | 8mm | | |

| | | | |
|--------|----------|-------|----------|
| WPA: | 鼓型双管接头 | WPUC: | 直通过管 |
| WPC: | 直通过管 | WPUL: | 弯头接管 |
| WPG: | 异径直通过管 | WPUT: | T型接管 |
| WPGJ: | 直通插杆接管 | WPUG: | 异径T型接管 |
| WPH: | 鼓型管接头 | WPW: | 异径Y型接管 |
| WPL: | 弯头接头 | WPWJ: | Y型插杆异径接管 |
| WPLGJ: | 异径L型接管 | WPWT: | Y型接头 |
| WPLJ: | L型插杆接管 | WPY: | Y型接管 |
| WPOC: | 带内六角直通过管 | WPYJ: | Y型插杆接管 |
| WPT: | T型接头 | | |

直通接头

(mm)

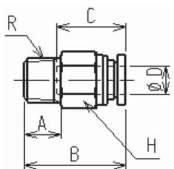

| 型号 | A | B | C | φD | H | R (外螺纹) | 净量 (g) |
|----------|------|------|------|----|------|---------|--------|
| WPC04-M5 | 4.0 | 20.1 | 14.5 | 4 | 8.0 | M5×0.8 | 4.5 |
| WPC04-01 | 8.0 | 20.1 | 14.5 | | 10.0 | R1/8 | 8.6 |
| WPC04-02 | 11.0 | 20.1 | 14.5 | | 14.0 | R1/4 | 17.3 |
| WPC06-M5 | 4.0 | 21.8 | 15.5 | 6 | 11.0 | M5×0.8 | 8.3 |
| WPC06-01 | 8.0 | 22.0 | 15.5 | | 11.0 | R1/8 | 9.2 |
| WPC06-02 | 11.0 | 22.8 | 15.5 | | 14.0 | R1/4 | 18.2 |
| WPC06-03 | 12.0 | 22.8 | 15.5 | 8 | 17.0 | R3/8 | 28.4 |
| WPC08-01 | 8.0 | 27.7 | 17.8 | | 13.0 | R1/8 | 13.7 |
| WPC08-02 | 11.0 | 25.7 | 17.8 | | 14.0 | R1/4 | 17.1 |
| WPC08-03 | 12.0 | 23.7 | 17.8 | 10 | 17.0 | R3/8 | 27.3 |
| WPC10-01 | 8.0 | 29.4 | 19.4 | | 17.0 | R1/8 | 22.2 |
| WPC10-02 | 11.0 | 32.4 | 19.4 | | 17.0 | R1/4 | 27.6 |
| WPC10-03 | 12.0 | 28.4 | 19.4 | 12 | 17.0 | R3/8 | 29.3 |
| WPC10-04 | 15.0 | 27.3 | 19.4 | | 21.0 | R1/2 | 48.5 |
| WPC12-02 | 11.0 | 35.4 | 22.4 | | 19.0 | R1/4 | 34.2 |
| WPC12-03 | 12.0 | 31.8 | 22.4 | 12 | 19.0 | R3/8 | 33.5 |
| WPC12-04 | 15.0 | 33.8 | 22.4 | | 21.0 | R1/2 | 54.8 |

带内六角直通接头

(mm)

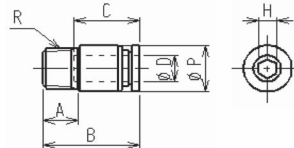

| 型号 | A | B | C | φD | H | φP | R (外螺纹) | 净量 (g) |
|-----------|------|------|------|-----|-----|------|---------|--------|
| WPOC04-M5 | 4.0 | 20.1 | 14.5 | 4 | 2.0 | 8.2 | M5×0.8 | 4.2 |
| WPOC04-01 | 8.0 | 20.1 | 14.5 | | 3.0 | 10.0 | R1/8 | 8.0 |
| WPOC06-M5 | 4.0 | 21.8 | 15.5 | | 6 | 2.0 | 11.0 | M5×0.8 |
| WPOC06-01 | 8.0 | 22.0 | 15.5 | 4.0 | | 11.0 | R1/8 | 8.6 |
| WPOC06-02 | 11.0 | 22.8 | 15.5 | 4.0 | | 13.5 | R1/4 | 16.8 |
| WPOC08-01 | 8.0 | 27.7 | 17.8 | 8 | 5.0 | 13.0 | R1/8 | 13.1 |
| WPOC08-02 | 11.0 | 25.7 | 17.8 | | 6.0 | 13.5 | R1/4 | 15.5 |
| WPOC08-03 | 12.0 | 23.7 | 17.8 | | 6.0 | 17.0 | R3/8 | 25.9 |
| WPOC10-01 | 8.0 | 29.4 | 19.4 | 10 | 5.0 | 15.5 | R1/8 | 18.0 |
| WPOC10-02 | 11.0 | 32.4 | 19.4 | | 6.0 | 15.5 | R1/4 | 23.3 |
| WPOC10-03 | 12.0 | 28.4 | 19.4 | | 8.0 | 17.0 | R3/8 | 25.7 |
| WPOC10-04 | 15.0 | 27.3 | 19.4 | 12 | 8.0 | 21.0 | R1/2 | 46.7 |
| WPOC12-02 | 11.0 | 35.4 | 22.4 | | 6.0 | 18.8 | R1/4 | 29.7 |
| WPOC12-03 | 12.0 | 31.8 | 22.4 | | 12 | 8.0 | 18.8 | R3/8 |
| WPOC12-04 | 15.0 | 33.8 | 22.4 | 8.0 | | 21.0 | R1/2 | 50.6 |

弯头接头

(mm)

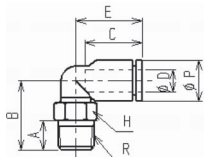

| 型号 | A | B | C | φD | E | H | φP | R (外螺纹) | 净量 (g) |
|----------|------|------|------|----|------|------|------|---------|--------|
| WPL04-M5 | 4.0 | 14.6 | 14.5 | 4 | 17.1 | 9.0 | 9.0 | M5×0.8 | 3.9 |
| WPL04-01 | 8.0 | 17.8 | 14.5 | | 17.1 | 10.0 | 9.0 | R1/8 | 4.8 |
| WPL04-02 | 11.0 | 20.8 | 14.5 | | 17.1 | 14.0 | 9.0 | R1/4 | 6.8 |
| WPL06-M5 | 4.0 | 15.7 | 15.5 | 6 | 18.0 | 9.0 | 11.2 | M5×0.8 | 7.3 |
| WPL06-01 | 8.0 | 18.9 | 15.5 | | 18.0 | 10.0 | 11.2 | R1/8 | 7.6 |
| WPL06-02 | 11.0 | 21.9 | 15.5 | | 18.0 | 14.0 | 11.2 | R1/4 | 15.0 |
| WPL06-03 | 12.0 | 22.9 | 15.5 | 8 | 18.0 | 17.0 | 11.2 | R3/8 | 22.4 |
| WPL08-01 | 8.0 | 20.3 | 17.8 | | 23.6 | 10.0 | 13.6 | R1/8 | 8.4 |
| WPL08-02 | 11.0 | 22.8 | 17.8 | | 23.6 | 14.0 | 13.6 | R1/4 | 15.9 |
| WPL08-03 | 12.0 | 23.8 | 17.8 | 10 | 23.6 | 17.0 | 13.6 | R3/8 | 22.5 |
| WPL10-01 | 8.0 | 23.6 | 19.4 | | 25.0 | 17.0 | 16.3 | R1/8 | 18.2 |
| WPL10-02 | 11.0 | 26.6 | 19.4 | | 25.0 | 17.0 | 16.3 | R1/4 | 20.2 |
| WPL10-03 | 12.0 | 26.1 | 19.4 | 12 | 25.0 | 17.0 | 16.3 | R3/8 | 22.8 |
| WPL10-04 | 15.0 | 29.1 | 19.4 | | 25.0 | 21.0 | 16.3 | R1/2 | 37.5 |
| WPL12-02 | 11.0 | 28.5 | 22.4 | | 32.2 | 17.0 | 19.7 | R1/4 | 26.7 |
| WPL12-03 | 12.0 | 28.0 | 22.4 | 12 | 32.2 | 17.0 | 19.7 | R3/8 | 28.4 |
| WPL12-04 | 15.0 | 31.0 | 22.4 | | 32.2 | 21.0 | 19.7 | R1/2 | 43.1 |

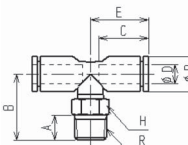

T型接头

(mm)

| 型号 | A | B | C | φD | E | H | φP | R (外螺纹) | 净量 (g) |
|----------|------|------|------|----|------|------|------|---------|--------|
| WPT04-M5 | 4.0 | 16.6 | 14.5 | 4 | 17.1 | 9.0 | 9.0 | M5×0.8 | 6.2 |
| WPT04-01 | 8.0 | 19.8 | 14.5 | | 17.1 | 10.0 | 9.0 | R1/8 | 8.4 |
| WPT04-02 | 11.0 | 22.8 | 14.5 | | 17.1 | 14.0 | 9.0 | R1/4 | 15.8 |
| WPT06-M5 | 4.0 | 17.7 | 15.5 | 6 | 18.0 | 9.0 | 11.2 | M5×0.8 | 7.7 |
| WPT06-01 | 8.0 | 20.9 | 15.5 | | 18.0 | 10.0 | 11.2 | R1/8 | 9.5 |
| WPT06-02 | 11.0 | 23.9 | 15.5 | | 18.0 | 14.0 | 11.2 | R1/4 | 17.3 |
| WPT06-03 | 12.0 | 24.9 | 15.5 | 8 | 18.0 | 17.0 | 11.2 | R3/8 | 24.7 |
| WPT08-01 | 8.0 | 23.5 | 17.8 | | 23.6 | 10.0 | 13.6 | R1/8 | 14.5 |
| WPT08-02 | 11.0 | 26.0 | 17.8 | | 23.6 | 14.0 | 13.6 | R1/4 | 21.3 |
| WPT08-03 | 12.0 | 27.0 | 17.8 | 10 | 23.6 | 17.0 | 13.6 | R3/8 | 28.9 |
| WPT10-01 | 8.0 | 25.8 | 19.4 | | 25.0 | 17.0 | 16.3 | R1/8 | 22.2 |
| WPT10-02 | 11.0 | 28.8 | 19.4 | | 25.0 | 17.0 | 16.3 | R1/4 | 25.7 |
| WPT10-03 | 12.0 | 28.3 | 19.4 | 12 | 25.0 | 17.0 | 16.3 | R3/8 | 28.3 |
| WPT10-04 | 15.0 | 31.3 | 19.4 | | 25.0 | 21.0 | 16.3 | R1/2 | 43.0 |
| WPT12-02 | 11.0 | 30.5 | 22.4 | | 32.2 | 17.0 | 19.7 | R1/4 | 36.4 |
| WPT12-03 | 12.0 | 30.0 | 22.4 | 12 | 32.2 | 17.0 | 19.7 | R3/8 | 39.0 |
| WPT12-04 | 15.0 | 33.0 | 22.4 | | 32.2 | 21.0 | 19.7 | R1/2 | 53.7 |

Y型接头

(mm)

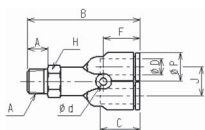

| 型号 | A | B | C | φD | φd | F | H | J | φP | R (外螺纹) | 净量 (g) |
|-----------|------|------|------|----|-----|------|------|------|------|---------|--------|
| WPWT04-M5 | 4.0 | 37.4 | 14.5 | 4 | 3.2 | 13.2 | 9.0 | 9.3 | 9.0 | M5×0.8 | 8.9 |
| WPWT04-01 | 8.0 | 40.6 | 14.5 | | 3.2 | 13.2 | 10.0 | 9.3 | 9.0 | R1/8 | 11.6 |
| WPWT04-02 | 11.0 | 43.6 | 14.5 | | 3.2 | 13.2 | 14.0 | 9.3 | 9.0 | R1/4 | 20.5 |
| WPWT06-M5 | 4.0 | 40.5 | 15.5 | 6 | 3.2 | 14.1 | 11.0 | 11.4 | 11.2 | M5×0.8 | 12.9 |
| WPWT06-01 | 8.0 | 43.7 | 15.5 | | 3.2 | 14.1 | 11.0 | 11.4 | 11.2 | R1/8 | 9.5 |
| WPWT06-02 | 11.0 | 46.7 | 15.5 | | 3.2 | 14.1 | 14.0 | 11.4 | 11.2 | R1/4 | 23.1 |
| WPWT06-03 | 12.0 | 47.7 | 15.5 | 8 | 3.2 | 14.1 | 17.0 | 11.4 | 11.2 | R3/8 | 35.2 |
| WPWT08-01 | 8.0 | 52.6 | 17.8 | | 3.2 | 18.6 | 13.0 | 14.2 | 13.6 | R1/8 | 21.9 |
| WPWT08-02 | 11.0 | 55.1 | 17.8 | | 3.2 | 18.6 | 14.0 | 14.2 | 13.6 | R1/4 | 25.1 |
| WPWT08-03 | 12.0 | 56.1 | 17.8 | 10 | 3.2 | 18.6 | 17.0 | 14.2 | 13.6 | R3/8 | 31.7 |
| WPWT10-01 | 8.0 | 53.0 | 19.4 | | 4.2 | 18.0 | 17.0 | 17.0 | 16.3 | R1/8 | 30.6 |
| WPWT10-02 | 11.0 | 56.0 | 19.4 | | 4.2 | 18.0 | 17.0 | 17.0 | 16.3 | R1/4 | 35.2 |
| WPWT10-03 | 12.0 | 58.0 | 19.4 | 12 | 4.2 | 18.0 | 17.0 | 17.0 | 16.3 | R3/8 | 40.8 |
| WPWT10-04 | 15.0 | 61.0 | 19.4 | | 4.2 | 18.0 | 21.0 | 17.0 | 16.3 | R1/2 | 59.8 |
| WPWT12-02 | 11.0 | 65.9 | 22.4 | | 4.2 | 23.9 | 19.0 | 20.0 | 19.7 | R1/4 | 53.7 |
| WPWT12-03 | 12.0 | 66.9 | 22.4 | 12 | 4.2 | 23.9 | 19.0 | 20.0 | 19.7 | R3/8 | 59.5 |
| WPWT12-04 | 15.0 | 70.9 | 22.4 | | 4.2 | 23.9 | 21.0 | 20.0 | 19.7 | R1/2 | 74.9 |

鼓型管接头

(mm)

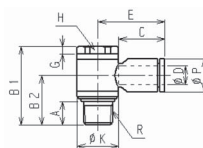

| 型号 | A | B1 | B2 | C | φD | E | G | H | φK | φP | R (外螺纹) | 净量 (g) |
|----------|------|------|------|------|----|------|-----|------|------|------|---------|--------|
| WPH04-M5 | 3.5 | 17.8 | 10.1 | 14.5 | 4 | 19.5 | 2.5 | 8.0 | 10.0 | 9.0 | M5×0.8 | 7.0 |
| WPH04-01 | 8.0 | 26.5 | 16.8 | 14.5 | | 21.5 | 2.5 | 13.0 | 14.0 | 9.0 | R1/8 | 14.7 |
| WPH04-02 | 11.0 | 34.0 | 22.0 | 14.5 | | 24.0 | 3.0 | 17.0 | 19.0 | 9.0 | R1/4 | 27.0 |
| WPH06-M5 | 3.5 | 17.8 | 10.6 | 15.5 | 6 | 20.5 | 2.5 | 8.0 | 10.0 | 11.2 | M5×0.8 | 7.8 |
| WPH06-01 | 8.0 | 26.5 | 16.8 | 15.5 | | 22.5 | 2.5 | 13.0 | 14.0 | 11.2 | R1/8 | 16.1 |
| WPH06-02 | 11.0 | 34.0 | 22.0 | 15.5 | | 25.0 | 3.0 | 17.0 | 19.0 | 11.2 | R1/4 | 28.7 |
| WPH06-03 | 12.0 | 39.8 | 25.3 | 15.5 | 8 | 26.7 | 4.0 | 21.0 | 22.4 | 11.2 | R3/8 | 51.4 |
| WPH08-01 | 8.0 | 26.5 | 17.5 | 17.8 | | 25.6 | 2.5 | 13.0 | 14.0 | 13.6 | R1/8 | 16.4 |
| WPH08-02 | 11.0 | 34.0 | 22.0 | 17.8 | | 28.1 | 3.0 | 17.0 | 19.0 | 13.6 | R1/4 | 29.4 |
| WPH08-03 | 12.0 | 39.8 | 25.3 | 17.8 | 10 | 29.8 | 4.0 | 21.0 | 22.4 | 13.6 | R3/8 | 52.7 |
| WPH10-01 | 8.0 | 34.0 | 22.7 | 19.4 | | 28.9 | 3.0 | 17.0 | 19.0 | 16.3 | R1/4 | 32.7 |
| WPH10-03 | 12.0 | 39.8 | 25.3 | 19.4 | | 30.6 | 4.0 | 21.0 | 22.4 | 16.3 | R3/8 | 55.7 |
| WPH10-04 | 15.0 | 44.8 | 28.8 | 19.4 | 12 | 32.9 | 5.0 | 24.0 | 27.0 | 16.3 | R1/2 | 90.7 |
| WPH12-03 | 12.0 | 39.8 | 26.7 | 22.4 | | 35.9 | 4.0 | 21.0 | 22.4 | 19.7 | R3/8 | 57.6 |
| WPH12-04 | 15.0 | 44.8 | 29.7 | 22.4 | | 38.2 | 5.0 | 24.0 | 27.0 | 19.7 | R1/2 | 92.8 |

鼓型双管接头

(mm)

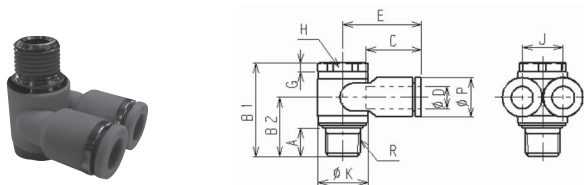

| 型号 | A | B1 | B2 | C | φD | E | G | H | J | φK | φP | R (外螺纹) | 净量 (g) |
|----------|------|------|------|------|----|------|-----|------|------|------|------|------------|-----------|
| WPA04-M5 | 3.5 | 17.8 | 10.1 | 14.5 | 4 | 18.6 | 2.5 | 8.0 | 9.3 | 10.0 | 9.0 | M5×0.8 | 9.2 |
| WPA06-01 | 8.0 | 26.5 | 16.8 | 15.5 | 6 | 22.0 | 2.5 | 13.0 | 11.4 | 14.0 | 11.2 | R1/8 | 18.4 |
| WPA08-02 | 11.0 | 34.0 | 22.0 | 17.8 | 8 | 28.1 | 3.0 | 17.0 | 14.2 | 19.0 | 13.6 | R1/4 | 46.6 |
| WPA10-02 | 11.0 | 34.0 | 22.7 | 19.4 | 10 | 27.5 | 3.0 | 17.0 | 17.0 | 19.0 | 16.3 | R1/4 | 72.0 |
| WPA10-03 | 12.0 | 39.8 | 25.3 | 19.4 | | 29.6 | 4.0 | 21.0 | 17.0 | 22.4 | 16.3 | R3/8 | 76.7 |
| WPA12-04 | 15.0 | 44.8 | 29.7 | 22.4 | 12 | 34.9 | 5.0 | 24.0 | 20.0 | 27.0 | 19.7 | R1/2 | 118.0 |

直通过管

(mm)

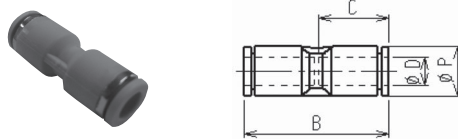

| 型号 | B | C | φD | φP | 净量 (g) |
|--------|------|------|----|------|-----------|
| WPUC04 | 30.2 | 14.5 | 4 | 9.0 | 3.1 |
| WPUC06 | 32.0 | 15.5 | 6 | 11.2 | 4.8 |
| WPUC08 | 40.2 | 17.8 | 8 | 13.6 | 8.8 |
| WPUC10 | 40.0 | 19.4 | 10 | 16.3 | 10.6 |
| WPUC12 | 54.8 | 22.4 | 12 | 19.7 | 20.9 |

弯头接管

(mm)

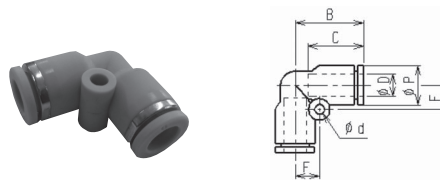

| 型号 | B | C | φD | φd | F | φP | 净量 (g) |
|--------|------|------|------|-----|------|------|-----------|
| WPUL04 | 17.1 | 14.5 | 4.0 | 3.2 | 6.0 | 9.0 | 3.2 |
| WPUL06 | 19.0 | 15.5 | 6.0 | 3.2 | 6.7 | 11.2 | 4.9 |
| WPUL08 | 23.6 | 17.8 | 8.0 | 3.2 | 8.5 | 13.6 | 9.4 |
| WPUL10 | 25.0 | 19.4 | 10.0 | 4.2 | 10.0 | 16.3 | 11.8 |
| WPUL12 | 32.2 | 22.4 | 12.0 | 4.2 | 12.0 | 19.7 | 22.5 |

T型接管

(mm)

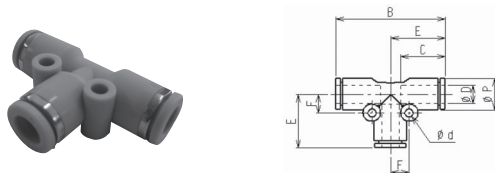

| 型号 | B | C | φD | φd | E | F | φP | 净量 (g) |
|--------|------|------|------|-----|------|------|------|-----------|
| WPUT04 | 34.2 | 14.5 | 4.0 | 3.2 | 17.1 | 6.0 | 9.0 | 4.6 |
| WPUT06 | 38.0 | 15.5 | 6.0 | 3.2 | 19.0 | 6.5 | 11.2 | 7.0 |
| WPUT08 | 47.2 | 17.8 | 8.0 | 3.2 | 23.6 | 9.0 | 13.6 | 11.1 |
| WPUT10 | 50.0 | 19.4 | 10.0 | 4.2 | 25.0 | 12.0 | 16.3 | 15.3 |
| WPUT12 | 64.4 | 22.4 | 12.0 | 4.2 | 32.2 | 14.0 | 19.7 | 29.8 |

Y型接管

(mm)

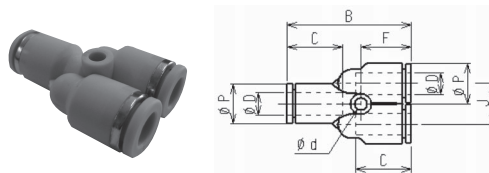

| 型号 | B | C | φD | φd | F | J | φP | 净量 (g) |
|-------|------|------|----|-----|------|------|------|-----------|
| WPY04 | 31.2 | 14.5 | 4 | 3.2 | 13.2 | 9.3 | 9.0 | 4.9 |
| WPY06 | 34.7 | 15.5 | 6 | 3.2 | 14.1 | 11.4 | 11.2 | 7.3 |
| WPY08 | 44.2 | 17.8 | 8 | 3.2 | 18.6 | 14.2 | 13.6 | 13.9 |
| WPY10 | 46.0 | 19.4 | 10 | 4.2 | 18.0 | 17.0 | 16.3 | 17.7 |
| WPY12 | 56.8 | 22.4 | 12 | 4.2 | 23.9 | 20.0 | 19.7 | 32.5 |

异径直通过管

(mm)

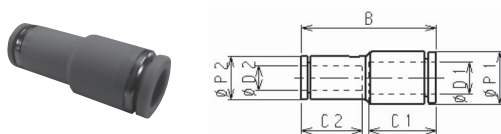

| 型号 | B | C1 | C2 | φD1 | φD2 | φP1 | φP2 | 净量 (g) |
|----------|------|------|------|-----|-----|------|------|-----------|
| WPG06-04 | 31.1 | 15.5 | 14.5 | 6 | 4 | 11.2 | 9.0 | 4.1 |
| WPG08-06 | 34.3 | 17.8 | 15.5 | 8 | 6 | 13.6 | 11.2 | 5.7 |
| WPG10-08 | 38.2 | 19.4 | 17.8 | 10 | 8 | 16.3 | 13.6 | 9.7 |
| WPG12-10 | 42.8 | 22.4 | 19.4 | 12 | 10 | 19.7 | 16.3 | 15.4 |

异径T型接管

(mm)



| 型号 | A | B | C1 | C2 | φd1 | φd2 | φD1 | φD2 | E | G | H | φK | 净量 (g) |
|-----------|------|------|------|------|-----|-----|------|------|------|------|------|-----|-----------|
| WPUG06-04 | 38.0 | 19.0 | 15.5 | 14.5 | 6 | 4 | 11.2 | 9.0 | 18.1 | 6.5 | 6.0 | 3.2 | 6.7 |
| WPUG08-06 | 47.2 | 23.6 | 17.8 | 15.5 | 8 | 6 | 13.6 | 11.2 | 20.0 | 8.5 | 8.0 | 3.2 | 9.6 |
| WPUG10-08 | 50.0 | 25.0 | 19.4 | 17.8 | 10 | 8 | 16.3 | 13.6 | 24.1 | 10.0 | 9.5 | 4.2 | 16.6 |
| WPUG12-10 | 64.4 | 32.2 | 22.4 | 19.4 | 12 | 10 | 19.7 | 16.3 | 25.5 | 12.0 | 10.0 | 4.2 | 28.1 |

异径Y型接管

(mm)

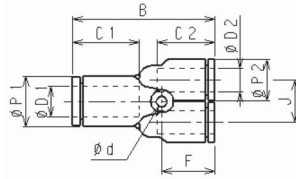

| 型号 | B | C1 | C2 | φD1 | φD2 | φd | F | J | φP1 | φP2 | 净量 (g) |
|----------|------|------|------|-----|-----|-----|------|------|------|------|--------|
| WPW06-04 | 32.5 | 15.5 | 14.5 | 6 | 4 | 3.2 | 13.2 | 9.3 | 11.2 | 9.0 | 5.0 |
| WPW08-04 | 37.7 | 17.8 | 14.5 | 8 | 4 | 3.2 | 13.7 | 11.4 | 13.6 | 11.2 | 8.0 |
| WPW08-06 | 38.1 | 17.8 | 15.5 | 8 | 6 | 3.2 | 14.1 | 11.4 | 13.6 | 11.2 | 14.3 |
| WPW10-06 | 42.6 | 19.4 | 15.5 | 10 | 6 | 3.2 | 17.2 | 14.2 | 16.3 | 13.6 | 22.8 |
| WPW10-08 | 43.2 | 19.4 | 17.8 | 10 | 8 | 3.2 | 17.8 | 14.2 | 16.3 | 13.6 | 14.8 |
| WPW12-08 | 50.5 | 22.4 | 17.8 | 12 | 8 | 4.2 | 17.6 | 17.0 | 19.7 | 16.3 | 33.1 |
| WPW12-10 | 50.9 | 22.4 | 19.4 | 12 | 10 | 4.2 | 18.0 | 17.0 | 19.7 | 16.3 | 25.5 |

直通插杆接管

(mm)

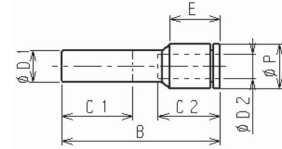

| 型号 | B | C1 | C2 | E | φD1 | φD2 | φP | 净量 (g) |
|-----------|------|------|------|------|-----|-----|------|--------|
| WPGJ06-04 | 36.1 | 15.5 | 14.5 | 11.3 | 6 | 4 | 9.0 | 2.8 |
| WPGJ08-04 | 36.9 | 17.8 | 14.5 | 11.3 | 8 | 4 | 9.0 | 3.2 |
| WPGJ08-06 | 39.5 | 17.8 | 15.5 | 12.6 | | 6 | 11.2 | 3.5 |
| WPGJ10-06 | 40.3 | 19.4 | 15.5 | 12.6 | 10 | 6 | 11.2 | 3.8 |
| WPGJ10-08 | 45.6 | 19.4 | 17.8 | 16.6 | | 8 | 13.6 | 5.5 |
| WPGJ12-08 | 46.6 | 22.4 | 17.8 | 16.6 | 12 | 8 | 13.6 | 6.5 |
| WPGJ12-10 | 46.6 | 22.4 | 19.4 | 15.0 | | 10 | 16.3 | 7.3 |

L型插杆接管

(mm)

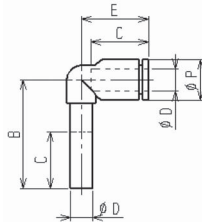

| 型号 | B | C | φD | E | φP | 净量 (g) |
|--------|------|------|----|------|------|--------|
| WPLJ04 | 23.5 | 14.5 | 4 | 17.1 | 9.0 | 3.0 |
| WPLJ06 | 29.6 | 15.5 | 6 | 18.0 | 11.2 | 4.7 |
| WPLJ08 | 32.8 | 17.8 | 8 | 23.6 | 13.6 | 6.0 |
| WPLJ10 | 36.2 | 19.4 | 10 | 25.0 | 16.3 | 7.9 |
| WPLJ12 | 39.9 | 22.4 | 12 | 32.2 | 19.7 | 21.4 |

异径L型接管

(mm)

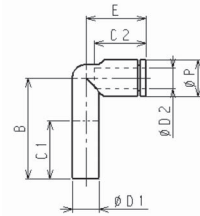

| 型号 | B | C1 | C2 | φD1 | φD2 | E | φP | 净量 (g) |
|------------|------|------|------|-----|-----|------|------|--------|
| WPLGJ06-04 | 28.5 | 15.5 | 14.5 | 6 | 4 | 17.1 | 9.0 | 3.3 |
| WPLGJ08-06 | 30.6 | 17.8 | 15.5 | 8 | 6 | 18.0 | 11.2 | 5.5 |
| WPLGJ10-08 | 33.8 | 19.4 | 17.8 | 10 | 8 | 23.6 | 13.6 | 11.0 |
| WPLGJ12-10 | 38.2 | 22.4 | 19.4 | 12 | 10 | 25.0 | 16.3 | 17.0 |

Y型插杆接管

(mm)

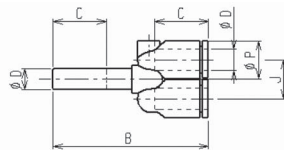

| 型号 | B | C | φD | J | φP | 净量 (g) |
|--------|------|------|----|------|------|--------|
| WPYJ04 | 37.8 | 14.5 | 4 | 9.3 | 9.0 | 5.5 |
| WPYJ06 | 45.0 | 15.5 | 6 | 11.4 | 11.2 | 7.2 |
| WPYJ08 | 53.1 | 17.8 | 8 | 14.2 | 13.6 | 9.1 |
| WPYJ10 | 56.0 | 19.4 | 10 | 17.0 | 16.3 | 23.1 |
| WPYJ12 | 63.4 | 22.4 | 12 | 20.0 | 19.7 | 30.8 |

Y插杆型异径接管

(mm)

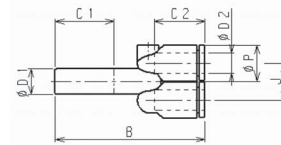

| 型号 | B | C1 | C2 | φD1 | φD2 | J | φP | 净量 (g) |
|-----------|------|------|------|-----|-----|------|------|--------|
| WPWJ06-04 | 42.8 | 15.5 | 14.5 | 6 | 4 | 9.3 | 9.0 | 5.7 |
| WPWJ08-06 | 45.5 | 17.8 | 15.5 | 8 | 6 | 11.4 | 11.2 | 7.3 |
| WPWJ10-08 | 53.1 | 19.4 | 17.8 | 10 | 8 | 14.2 | 13.6 | 9.1 |
| WPWJ12-10 | 58.0 | 22.4 | 19.4 | 12 | 10 | 17.0 | 16.3 | 24.1 |