

# Rotary vane vacuum pump CRV series



- Rotary vane vacuum pump
- Integrated cooling fan
- Filter mounted

## How to order

①	16V	-	2	②
① Body	16V   Motor power 0.40kW 25V   Motor power 0.75kW		2	② Voltage
				2   Three phase 220V

## Maintenance parts

- Vane  
CRV-16V-V (For CRV-16V)  
CRV-25V-V (For CRV-25V)
- Element (For 16V,25V)  
CRV-F
- Vacuum filter  
AF001-3 (Port thread : Rc1/4)

## Specifications

Model	Unit	CRV-16		CRV-25	
		50	60	50	60
Vacuum (air) flow	l/min	230	280	400	480
Max. vacuum pressure	kPa	-86.3			
Vacuum pressure	kPa	-59.7			
Motor		Three phase			
Voltage	V	220			
Motor power	kW	0.4		0.75	
Noise level	dB	64/65		64/65	
Ambient temperature	°C	7-40			
Mass	kg	22		26	

## Dimensions

Unit:mm <inch>

### CRV-16

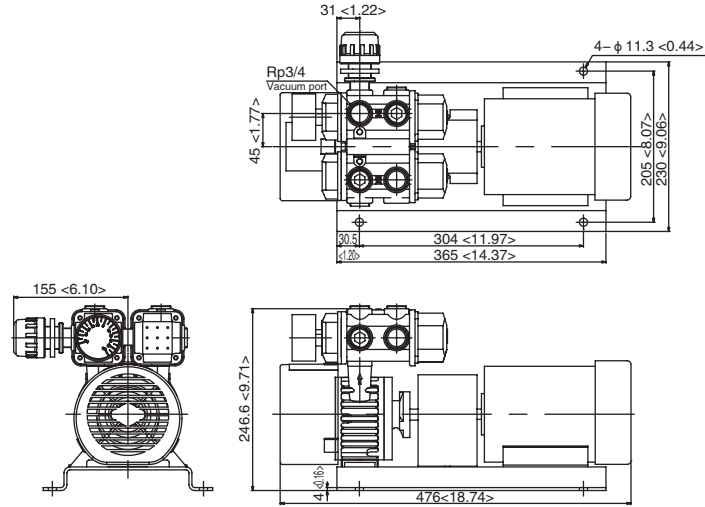

### CRV-25

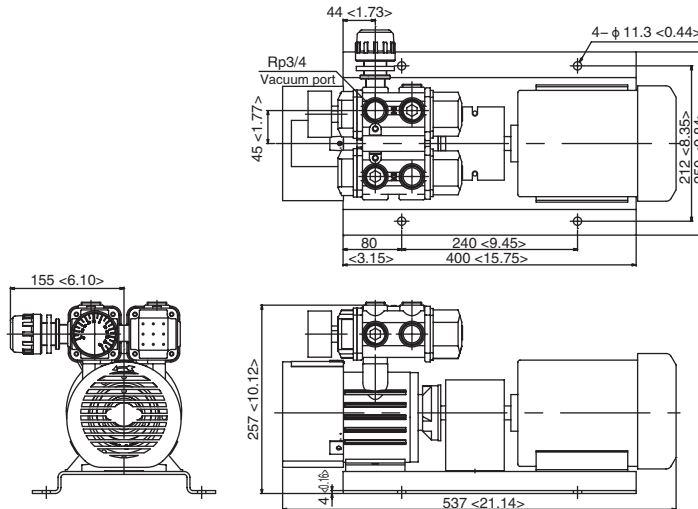

## Performance charts

